

and a diffusion constant approximately that of the latter, each have molecules diverging widely from the spherical shape.

Summary

1. Measurements of the molecular weight of the hemocyanin of the horseshoe crab *Limulus polyphemus* have been made in dilute phosphate buffer solution at P_H 6.63 in concentrations of 0.03–0.09% of protein by the sedimentation velocity and the sedimentation equilibrium methods in the ultracentrifuge.

2. Both methods indicate that at concentrations of about 0.06–0.1% the protein undergoes decomposition.

3. The existence of this decomposition has been confirmed by measurements of the ultraviolet absorption, as the values of ϵ/c increase with dilution in this range of concentrations.

4. The decomposition is largely if not completely reversible and a protein of the same molecular weight and ϵ/c as that originally used may be precipitated from the dilute solutions by removing electrolytes by dialysis.

5. The sedimentation velocity method indicates for the hemocyanin of *Limulus polyphemus* a probable molecular weight of 2.04×10^6 under the conditions described.

UPSALA, SWEDEN

[CONTRIBUTION FROM THE LABORATORY OF PHYSICAL CHEMISTRY OF THE UNIVERSITY OF UPSALA]

THE INFLUENCE OF THE HYDROGEN-ION ACTIVITY UPON THE STABILITY OF THE HEMOCYANIN OF HELIX POMATIA

BY THE SVEDBERG AND FRANCIS F. HEYROTH¹

RECEIVED OCTOBER 2, 1928

PUBLISHED FEBRUARY 5, 1929

The previously reported determinations by ultracentrifugal methods² of the molecular weight of the hemocyanin isolated from the blood of the vineyard snail, *Helix pomatia*, were made upon solutions buffered to P_H 4.7, which is not far removed from P_H 5.2, the isoelectric point of the protein. This reaction was adopted to obviate the disturbing variation in the diffusion constant which in preliminary experiments at P_H 8.0 had been found to vary approximately inversely as the centrifugal force applied. As it was also noted that at P_H 3.8 the hemocyanin molecule appeared to break up into smaller units of undetermined size, a further study of this protein was deemed advisable in order to determine the region within which its huge molecules (of molecular weight 5,000,000 at P_H 4.7 in solutions containing 0.09% of protein) are stable. A similar series

¹ Fellow in Medicine of the National Research Council.

² Svedberg and Chirnoaga, THIS JOURNAL, 50, 1399 (1928).

of measurements of the molecular weight of carboxyhemoglobin³ at various hydrogen-ion activities had indicated that protein to be stable over the range from P_H 6.0 to 9.05.

Experimental

Material Used.—A suspension of dialyzed hemocyanin crystals prepared by Chirnoaga for the previously reported investigation and there described in detail was employed. The crystals were dissolved in 100 cc. of distilled water to form a 1.78% solution by the aid of only 1.5 cc. of an acetic acid–sodium acetate buffer of P_H 4.7. Just before starting each of the centrifuging experiments, a 1:20 dilution was made from this stock solution into a buffer solution of the desired reaction. The buffers used were sodium acetate–acetic acid mixtures over the range of P_H 5.62 and less, and mixtures of the primary and secondary sodium phosphates over the more alkaline range. In the former case the sodium-ion concentration was kept constant at 0.02 molar and the amount of acetic acid varied to give the required P_H . In the case of the phosphate buffers, the ionic strength of the solution was maintained constant at 0.0225, the relative volumes of $M/15$ solutions of the two salts necessary to

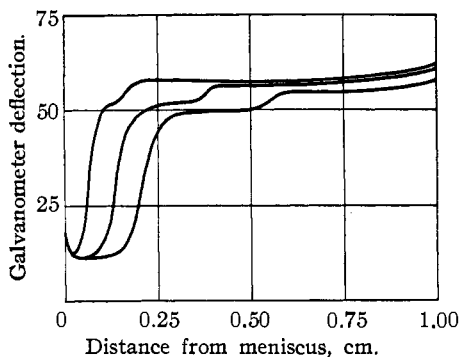

Fig. 1.

give the desired reactions being calculated by the method of Cohn.⁴ In most cases the reported P_H values were, however, determined electrometrically upon additional samples of the solutions prepared as for the actual runs. The concentration of the protein used was 0.089% in all except the runs at P_H 3.8, in which it was somewhat higher. The value 0.738 at 20° was used for the partial specific volume in those few instances in which values for the molecular weight are reported.

The material used contained a small quantity of a substance which moved in the centrifugal field somewhat more rapidly than the hemocyanin proper. This made itself evident by producing a second sedimentation boundary, appearing at the top of the usual concentration–distance curves, as shown in Fig. 1. This contamination in no way altered the sedimentation of the hemocyanin, as the heavier material was centrifuged down during the early part of each run. As may be seen from the results obtained at P_H 4.7, reported in Table I, the specific sedimenta-

³ Svedberg and Nichols, *THIS JOURNAL*, **49**, 2920 (1927).

⁴ Cohn, *ibid.*, **49**, 173 (1927).

tion velocity and diffusion constant (and therefore molecular weight) checked very well with the values previously published and included in the table for comparison. For experiments made some months later upon the reversibility of the disintegration process to be described below, a fresh solution was employed, prepared by redissolving the precipitate obtained by redialyzing what remained of the former solution. This solution was free from the heavier material, so that in a run at P_H 4.7 only one boundary was observed.

The Determination of Molecular Weights.—The sedimentation velocity method was employed exclusively in this work. It is based upon the equation, $M = RTs/D(1 - V\rho)$, in which s is the specific sedimentation velocity or rate of movement of the boundary under unit centrifugal

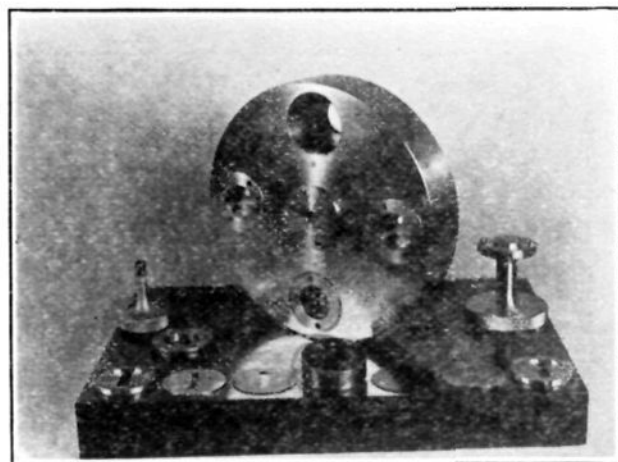

Fig. 2.

force in cm. per second, D is the diffusion constant of the protein in cm.²/sec., V the partial specific volume of the protein, ρ the density of the solution, R the gas constant, and T the absolute temperature.⁵ Except for the runs at P_H 3.8 and 3.9, which were performed in the oil-turbine centrifuge operated at 42,000 and 25,000 r.p.m. (centrifugal force 102,000 and 36,000 times the force of gravity), respectively, the runs were all made at a speed

of approximately 8400 r.p.m. (centrifugal force 4100 times the force of gravity) in a new ultracentrifuge designed for low and medium centrifugal fields.

The cells employed were each made from two round quartz plates 30 mm. in diameter and 5 mm. thick, cemented to a third plate of the same diameter and 8 mm. thick. This had cut in it a sectorial aperture of 5°. The cell was cemented to a steel collar having an opening coincident with the opening of the sectorial cell. The steel collar containing the cell was supported by a system of sectorial disks and diaphragms in a hole drilled in the rotor of the centrifuge. Actually only a 3° sector was exposed to radiations passing through the cell when supported in the rotor. The latter, 15 cm. in diameter and 3 cm. in thickness, was arranged to receive four cells. In practice, however, only two cells were used at a time, the spaces for the other two being filled by aluminum blanks. Fig. 2 shows the rotor, one of the cells, and the various disks and diaphragms. The rotor was supported upon a vertical rotating shaft carrying two ball bearings, which in its turn was supported by a flexible steel rod. The energy of rotation was delivered by a motor and transferred to the rotating shaft by an endless screw device and a system of special couplings. To prevent heating the rotor was surrounded by hydrogen at atmospheric pressure, confined within a casing about the

⁵ Svedberg and Nichols, *THIS JOURNAL*, 49, 2920 (1927).

rotor. To further ensure constancy of the temperature during each run the casing within which the rotor turned was immersed in a water thermostat regulated to maintain a temperature of 20° (Fig. 3).

The casing of the centrifuge was also provided with two quartz windows, each fitted with an electromagnetic shutter. The optical system used is shown diagrammatically in Fig. 4. The ultraviolet radiations from a quartz mercury vapor lamp B, with *matte surface for uniformity of illumination, mounted in a water-cooled lamp-house A* were made to pass a 6-cm. water filter C, an 8-cm. bromine filter D, and an 8-cm. chlorine filter E. The radiations, which were thus restricted to those with wave lengths shorter than $290\mu\mu$,⁶ were reflected vertically by the prism F through the cell I carried by the rotor H of the centrifuge G. The quartz lens K, of focal length 64.5 cm. and provided with an aperture of $f/25$, threw an image of the sectorial aperture in double natural size upon a photographic plate (Imperial Process) in a camera mounted in a room above that containing the centrifuge. The length of exposure was thirty seconds, except in two runs at P_H 8.2 and 3.4, in which shorter times were used.

Table I presents the results obtained in each of the runs. In it Col. 1 gives the P_H , Col. 2 the specific sedimentation velocity and Col. 3 the diffusion constant, obtained from the blurring of the boundary. In Col. 4 are given molecular weights for those of the runs in which obvious disintegration of the molecules did not occur. The variation of s and D with P_H is shown graphically in Fig. 5, dotted lines being employed in the regions in which disintegration is believed to have occurred.

Certain of the values for the "diffusion constant" are enclosed in parentheses to indicate that these values cannot be considered as representing the diffusion of molecules of uniform size. Table II and Fig. 6 illustrate the criterion by means of which it may be determined whether, in a given run, the concentration-distance gradients at the protein solution-solvent boundaries at successive time intervals may be ascribed entirely to the

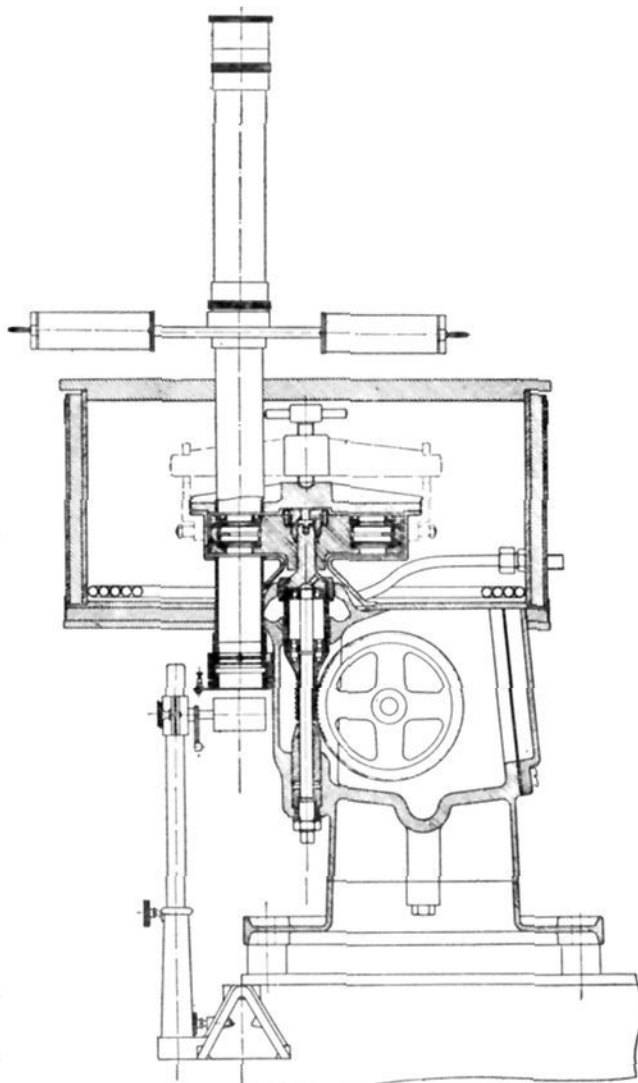

Fig. 3.

⁶ Svedberg and Nichols, *THIS JOURNAL*, **48**, 3081 (1926).

TABLE I

VARIATION OF SPECIFIC SEDIMENTATION VELOCITY AND DIFFUSION CONSTANT WITH P_H

P_H	s in cm./sec. $\times 10^{13}$	D , diff. const., cm. ² /day	M mol. wt. $\times 10^{-6}$	P_H	s in cm./sec. $\times 10^{13}$	D , diff. const., cm. ² /day	M , mol. wt. $\times 10^{-6}$
3.8	0.739	(0.0960)	...	4.7	8.55-10.3 ^a	0.0140, 0.0165 ^b	Mean 4.91
3.8 ^c	0.574	(0.107)	...	5.62	9.79	0.0127	(6.37)
3.9A	0.765	(0.161)	...	6.3	9.79	0.0123	(6.44)
3.9B	6.01	(0.0068)	(7.1)	7.2	9.60	0.0166	(4.60)
4.1	6.66	(0.0503)	...	7.36	9.61	0.0123	(6.30)
4.3	9.23	(0.0315)	...	7.46 ^d	9.43	0.0128	(6.03)
4.4	9.54	0.0174	...	7.65 ^d	8.88	0.0299
4.5	9.88	0.0138	5.70	7.96 ^e	7.99	0.0683
4.7	10.1	0.0155	5.24	8.0	2.09 est.
				8.2 ^f	8.24, 2.20	0.0196

^a Mean, 9.42, determined by Chirnoaga.^b Mean, 0.0154.^c After 9 days.^d A trace of non-centrifugible substance.^e Slowly centrifuging and non-centrifuging substances.^f Much non-centrifugible material.

Fig. 4.

diffusion of the molecules against the force of centrifugation. If this is true, as is approximately the case, in Table II from P_H 4.5 to 7.46 the successive calculated values of D fluctuate about a mean which may be taken as the diffusion constant. If, however, the concentration-distance gradients at the boundaries are in part due to the increasing separation of molecules of not very different frictional resistances moving toward the bottom of the cell at different rates or moving downward at the same and diffusing backward at different rates, the successive calculated D values increase with some fluctuations throughout the run. It is the mean values of such runs (obtained at P_H values < 4.7 and > 7.46) which have been placed in parentheses, as they cannot be

TABLE II
 "APPARENT DIFFUSION CONSTANTS" CALCULATED AT SUCCESSIVE THIRTY-MINUTE
 INTERVALS DURING EACH RUN
 Acid to Isoelectric Point

	4.7	4.5	4.4	P_H 4.3	4.1	3.9	3.8
1	0.0076	0.0062	0.0112	0.0076	0.0278	0.0095	0.0052
2	.0132	.0124	.0117	.0113	.0195	.0252	.0440
3	.0149	.0139	.0134	.0151	.0258	.0449	.0663
4	.0180	.0134	.0149	.0206	.0275	.0864	.184
5	.0156	.0125	.0160	.0278	.0407	.180
6	.0152	.0154	.0186	.0282	.0510	.214
7	.0158	.0130	.0221	.0486	.0608	.255
80147	.0213	.0459	.0811	.321
90155	.0215	.0548	.0967	.315
Mean ^a	.0155	.0138	.0174	.0312	.0503	.161	.107

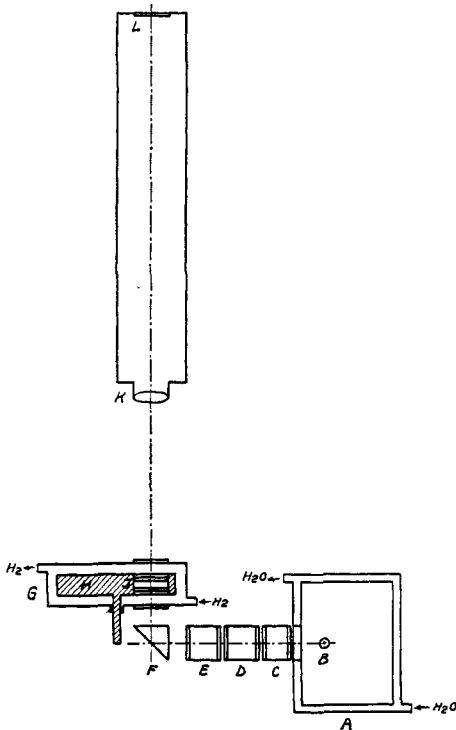
Alkaline to Isoelectric Point

	5.62	6.3	7.2	P_H 7.36	7.46	7.65	7.9
1	0.0076	0.0103	0.0089	0.0058	0.0103	0.0070	0.0111
2	.0116	.0110	.0081	.0116	.0105	.0152	.0127
3	.0127	.0134	.0209	.0128	.0114	.0153	.0174
4	.0118	.0130	.0167	.00990210	.0303
5	.0144	.0104	.0173	.0140	.0129	.0263	.0568
6	.0151	.0117	.0166	.0133	.0140	.0246	.119
7	.0123	.0163	.0166	.0117	.0146	.0322	.103
8	.0145	.0127	.0192	.0124	.0136	.0475	.139
9	.009101870567
Mean	.0127	.0123	.0166	.0123	.0128	.0299	.068

^a In calculating the mean values the first value of each series was omitted, as during the first thirty minutes sedimentation had not progressed far enough to give a boundary from which the diffusion constant could be accurately obtained.

used for the calculation of molecular weights. In Fig. 6 lines have been drawn through the successive D values in three of the runs plotted on a scale which magnifies any drift: the slopes of the curves, plotting each in this manner (only three are given in Fig. 6 to avoid confusion), indicate a gradual loss of the uniformity of the molecules which exists near the isoelectric point as the solutions are made increasingly acid or alkaline. When the limits of the range 4.7-7.46 are exceeded, the slopes of such lines increase enormously. The increasing D values shown in the dotted portions of Fig. 5 are thus in large part due to this separation of unlike particles and in small part to the greater diffusibility of the smaller ones present.

Discussion of Results

Fig. 5 shows that the specific sedimentation velocity remains approximately constant at $9.61-10.00 \times 10^{-12}$ between P_H 4.5 and 7.36; at about these limits it decreases at first gradually and then very rapidly. The protein is thus stable between a reaction not greatly acid to its iso-

electric point and one which corresponds approximately with that (7.4-7.8) believed to prevail in the snail's blood.⁷

The decrease in the rate of movement in the centrifugal field at reactions acid to *PH* 4.5 and alkaline to *PH* 7.36 may be regarded as indicating the

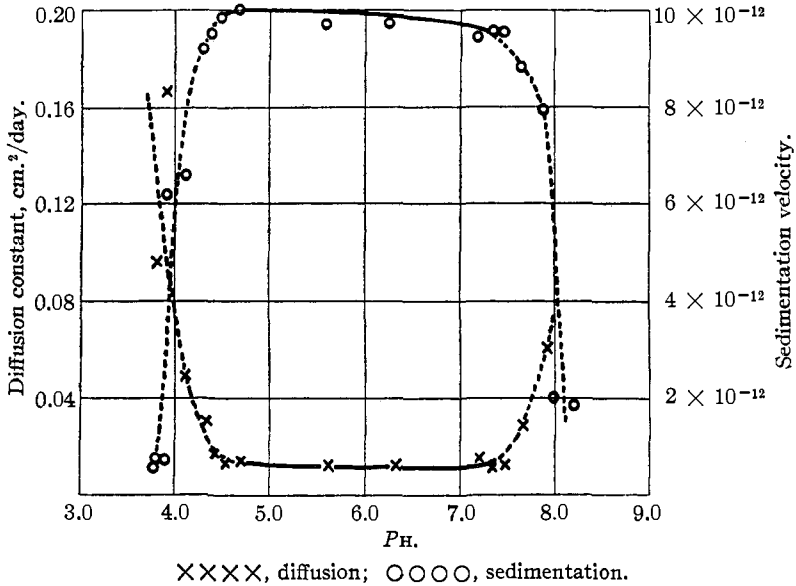

Fig. 5.

presence of increasing numbers of smaller units resulting from a disintegration of the hemocyanin under the influence of the hydrogen or hydroxyl ions. The *s* values given on the descending dotted portions of the curve are therefore only to be regarded as mean sedimentation rates for mixtures

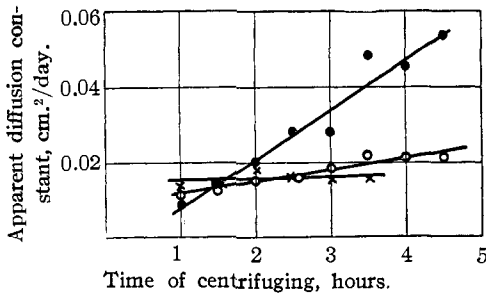

Fig. 6.

in varying proportions of particles of various sizes. In support of the view that molecular disintegration occurs in these regions may be mentioned four experimental facts.

1. The previously mentioned drift in the apparent diffusion constants with time becomes enormous here.

2. The concentration-distance curves obtained during the early portion of a run at *PH* 3.9 and 25,000 r.p.m., shown (uncorrected for the sector shape of cell and for in-

⁷ Duval, *Compt. rend.*, 179, 1629 (1924); Damboviceanu, *Compt. rend. soc. biol.*, 89, 261 (1923).

creased acceleration with distance) in Fig. 7, exhibit two boundaries moving at different rates and corresponding to different particle sizes or to two mixtures each composed of particles not greatly unlike. A similar effect was noted in the two most alkaline runs.

3. Runs made with solutions which had been kept at P_H 3.8 for differing periods of time give different values for the specific sedimentation velocity. The decrease with time suggests that the acid decomposition which is effected in large part very rapidly, continues at a lower rate. Thus s determined immediately after bringing the protein to P_H 3.8 was 0.739×10^{-12} . After nine days at this reaction, it decreased to 0.574×10^{-12} .

4. The Tyndall cone is much diminished in intensity in the acid and alkaline solutions.

Our value of approximately 2.0

for s at P_H 8.0 was much lower than the values 5.63 – 6.60×10^{-12} found in the previous investigation. An explanation is afforded by the run at P_H 8.2, in which the form of the sedimentation curves indicated the presence

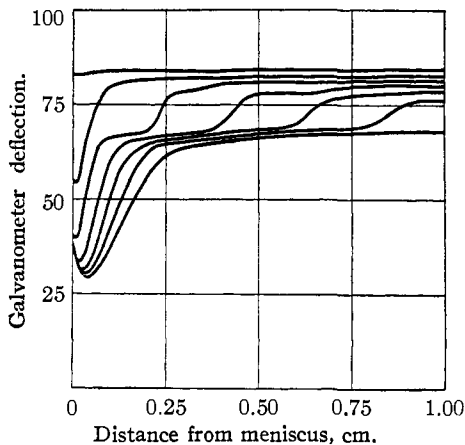

Fig. 7.

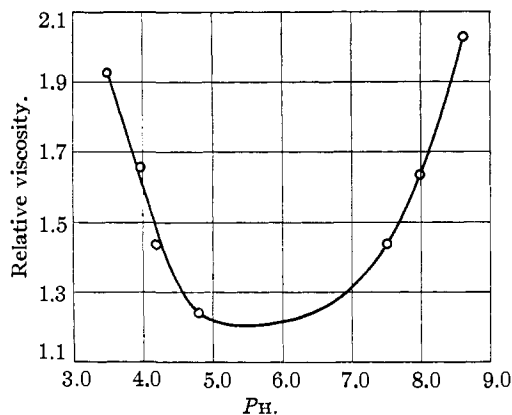

Fig. 8.

of a small amount of material moving with a velocity s (8.24×10^{-12}) which is somewhat less than that of the protein, near its isoelectric point, together with some material of s about 2.2×10^{-12} , and a large quantity of material non-centrifugible at 8000 r.p.m. The presence of the latter was indicated by the fact that the light absorption by the liquid between the protein boundary and the meniscus was much greater

than that of the buffer solvent photographed in the same cell. It corresponded to that of a protein solution 40% as concentrated as that (0.089%) used in the experiment. Solutions in the neighborhood of P_H 8.0 thus appear to contain particles the sizes of which are distributed about three

values. The relative amounts of the material in each of these magnitudes appears to vary rapidly with time and slight alterations in P_H . The s values on the alkaline side are somewhat less reproducible than those on the acid side of the stability region.

In Fig. 8 is reproduced the curve obtained by Stedman and Stedman⁸ for the relation of the viscosity of the dialyzed serum of the snail, *Helix*, to the P_H . The curve shows increases in the relative viscosity amounting almost to double, in exactly those P_H regions in which the specific sedimentation velocity falls off most sharply. These investigators furnish no measurements between P_H 4.7 and 7.3. It might at first be supposed that the increased viscosity retards the movement of the protein under the centrifugal field. It is, however, the viscosity of the solvent and not that of the protein solution as such which is believed to influence the rate of centrifugation. Even though this were not the case, the viscosity changes in the dilute solutions employed would be insufficient to account for the observed drop in the sedimentation velocity.⁹ The rising values for the diffusion constant in these regions would be entirely inexplicable upon such a supposition. Sufficient independent evidence has also been presented to indicate that a disintegration of the molecules actually occurs in these regions.

It is therefore possible that, on the other hand, the dispersion of the protein into smaller units may have been in part at least responsible for the increase in viscosity observed by Stedman and Stedman. An increase in the viscosity of sulfur sols attending a diminution in the size of the particles present has been noted by Odén.¹⁰

To the suggestion of Pauli¹¹ that the increased viscosity of the solutions of proteins away from their isoelectric points is due to increased hydration accompanying the formation of the protein ions, may be added, at least in the case of hemocyanin, the possibility that it may be in part due to the increase in dispersion resulting from a disintegration of the molecules. The analysis by Smoluchowski¹² of the limits of applicability of the Einstein equation for the variation of the viscosity of a colloidal suspension with its volume concentration indicates that it may only be expected to hold when, among other conditions, the ratio of the particle radius to the distance between the particles is small. As in snail blood the diameter of the hemocyanin molecules is about two-thirds the distance between the

⁸ Stedman and Stedman, *Biochem. J.*, **21**, 541 (1927).

⁹ The non-centrifugible material present at P_H 8.0 may, however, be considered to be a portion of the solvent within which the heavier units are moving, and the increase in viscosity which its presence imparts to the buffer solution may aid in lowering the sedimentation rate of the larger unattached or partly disintegrated molecules.

¹⁰ Odén, *Nov. Act. Reg. Soc. Scient. Upsala*, [4] **3**, 85 (1913).

¹¹ Pauli, *Kolloid-Z.*, **40**, 185 (1926).

¹² Smoluchowski, *ibid.*, **18**, 190 (1916).

surfaces of the adjacent molecules, the Einstein equation need not be expected to apply to viscosity changes in the serum studied by Stedman and Stedman, and accordingly its implication that the degree of dispersion of the particles is without influence upon the viscosity need not be binding.

The determination of the magnitudes of the particles formed by the acid or alkaline disintegrations of the hemocyanin must be postponed until greater centrifugal fields are available. The results of sedimentation experiments at 42,000 r.p.m. indicate that even at P_H 3.8 all of the light-absorbing material present occurs in particles of size sufficient to move measurable distances in the short times within which runs are completed, since the light absorption in that portion of the liquid between the protein boundary and the meniscus corresponds to that of the pure buffer employed as solvent. This appears to exclude the possibility that the acid decomposition proceeds far enough to result in the formation of amino acids, the motion of which would not be measurable under the conditions described. The light-absorbing units which result from the *alkaline* disintegration are not, however, as completely removed from that part of the liquid from which most of the protein molecules have been centrifuged. Small amounts of such non-centrifugible material were noted in every run made at a P_H greater than 7.4, so that it is probable that the disintegration induced by hydroxyl ions proceeds somewhat further than that due to hydrogen ions.

The Reversibility of the Disintegrations.—Some months after the conclusion of these experiments a number of additional runs were made to determine whether or not the acid breakdown of the hemocyanin is reversible. Crystals freshly dialyzed from the remainder of the stock solution used in the earlier experiments were dissolved by the addition of a small amount of buffer solution to form a stock solution containing 1.66% of protein at P_H 4.7. When diluted to 0.087%, this was found free from material non-centrifugible at 8000 r.p.m., and its specific sedimentation velocity checked well with that previously obtained. One of the runs was made at P_H 3.4, attained by adding only the acid of the acetic acid-sodium acetate buffer required to make a similar dilution at P_H 4.7. At 8000 r.p.m. only a small fraction of the light-absorbing material present underwent sedimentation, and this at a rate which could be only roughly estimated as 0.8 that of the hemocyanin in its stable region. The light absorption in the region which might be expected to contain only buffer solution corresponded instead to that found in a solution containing 52% of the protein present in the solution used. Another sample which had stood at P_H 3.4 for about eight hours was brought to P_H 4.7 by the addition of the requisite amount of sodium acetate. The Tyndall cone, which had not been entirely destroyed by the acid treatment, was markedly increased in intensity and a small amount of a coarse precipitate was pro-

duced at the same time. After several hours, a run showed the presence of non-centrifugible material corresponding in light absorption to a solution containing but 19% (21% in a second experiment) of the amount of hemocyanin in the original solution, indicating that the acid decomposition had been partly reversed. In a third experiment, in which the acid treatment was maintained for only one hour before restoring the P_H to 4.7, a large proportion of molecules of the original size were reformed, and the amount of non-centrifugible material was correspondingly less, as the light absorption equaled that of a solution of 12% of the original protein concentration. In all three of these experiments the forms of the sedimentation curves indicated the presence of smaller particles in admixture. It thus appears that the first products which result from the acid-induced decomposition of the hemocyanin may reunite when the solution is restored to P_H values at which it is stable. Such a process is attended by some loss of material by precipitation and is never quite complete. On maintaining the acid reaction for longer periods a further irreversible splitting appears to ensue.

The Region of Stability.—At P_H 4.7¹³ both the specific sedimentation velocity and the diffusion constant have maximal values. As the P_H is made increasingly acid to this or increasingly alkaline beyond the isoelectric point, both of these values decrease progressively and gradually. This effect may possibly be explained as due to progressively increasing hydration of the protein molecules under the influence of the acid or alkali. The theoretical effect of hydration would be a lowering of both the specific sedimentation velocity and the diffusion constant by the same fraction of their values for material at the isoelectric point. Calculations showed that the new values to be expected were each of the molecules covered by a monomolecular layer of water, would be in the neighborhood of 97.4% of the corresponding values at the isoelectric point. The decreasing values of s (Table I), as the P_H values at which decomposition occurs are approached, are, within the limits of accuracy of these measurements, in accord with the supposition that the decomposition of the molecules is preceded by their hydration.

The diffusion constants also diminish from the region of the isoelectric point to the regions of beginning decomposition. The decrease is, however, greater than that of the sedimentation velocity. This discrepancy is somewhat obscured by the fact that even in this region there is a slight and gradually increasing drift in the diffusion values obtained at successive time intervals. Thus each of the mean values plotted in Fig. 5 is slightly too great, the errors increasing as the regions of decomposition are approached. This excess diminution of the diffusion constants over that

¹³ As this series of measurements was completed before it was learned that the isoelectric point of the protein is 5.2, no run was performed at that P_H .

to be expected as the result of hydration, while apparently slight, is nevertheless sufficient to lead to relatively great errors (20%) in the molecular weights calculated by their aid. The diminution in the diffusion may possibly be explained as due to the mutual interaction of the charges upon the ions which are formed in increasing relative amounts as the reaction is brought away from the isoelectric point. The great size and therefore proximity of the ions would render such an effect likely. Such interionic forces would not alter the rate of sedimentation of the molecules and ions as a group. In this respect they would be analogous to or identical with the forces postulated in the previous communication to account for the diminished diffusion and only slightly diminished sedimentation rate observed in hemocyanin solutions at P_H 4.7 as the concentration of the protein is increased. The diminution of diffusion resulting from the presence of charged ions in close proximity tends to obscure itself in the graphical records of the sedimentation of the protein, as it may itself be in part responsible for the slight drift with time in the diffusion values obtained in this region. The greater diffusibility of the uncharged molecules over that of the ions would tend to cause an increase in the blurring of the boundary with time.

Summary

1. The variation of the specific sedimentation velocity and the diffusion constant of the hemocyanin of *Helix pomatia* have been measured over the range of P_H from 3.8 to 8.2.

2. Hemocyanin in 0.089% concentration in dilute acetate and phosphate buffer solutions from P_H 4.5 to 7.4 possesses a molecular weight of five million.

3. As these limits of P_H are approached, the protein molecules become hydrated and as the limits are exceeded rapidly undergo disintegration into smaller particles of undetermined magnitude.

4. The acid disintegration is in its earliest stages reversible, but the disintegration of the products first formed continues slowly and is in its later stages irreversible.

5. The P_H ranges within which the disintegration occurs are the same as those within which the viscosity of snail serum is known to increase rapidly.